

TECHNICAL PAPER

Evolution of Power Capacitors for Electric Vehicles

Gilles Terzulli

KYOCERA AVX Components Corporation
Avenue du Colonel Prat 21850
St Apollinaire France

Abstract

Electric vehicles are in widespread use. Hybrid cars are now a common sight on our roads as people look to find more environmentally-friendly forms of personal transport, and there are many other commercial and public electric vehicles, such as trains, trams, buses and industrial trucks and equipment in everyday use. The electronic systems and components that have enabled the realisation of such a wide variety of electric vehicles have all experienced a major evolution, including the DC link power capacitor.

The purpose of capacitors in electric vehicles is to prevent ripple currents from reaching back to the power source, and to smooth out DC bus voltage variations. Capacitors are also used to protect semiconductors – originally thyristors, but now IGBTs. Metallised film has become the capacitor technology of choice for electric vehicle and other medium and high power applications; this article explains why using worked examples.



Electric vehicles are in widespread use. Hybrid cars are now a common sight on our roads as people look to find more environmentally-friendly forms of personal transport – and as a reaction to spiralling oil prices - and there are many other commercial and public electric vehicles, such as trains, trams, buses and industrial trucks and equipment in everyday use. The electronic systems and components that have enabled the realisation of such a wide variety of electric vehicles have all experienced a major evolution, including the DC link power capacitor.

The purpose of capacitors in electric vehicles is to prevent ripple currents from reaching back to the power source, and to smooth out DC bus voltage variations. Capacitors are also used to protect semiconductors – originally thyristors, but now IGBTs.

Metallised film has become the capacitor technology of choice for electric vehicle and other medium and high power applications. There are several reasons for this.

One major advantage is the ability of film capacitors to overcome internal defects. The latest dielectric films used for DC filter capacitors are coated with a very thin metallic layer. In the case of any defect, the metal evaporates and therefore isolates or fuses the defect, effectively self-healing the capacitor. The total capacitance is divided into elementary cells (sometimes several million) protected by fuse gate. If there is a weak point, the particular cell where the weak point is located will be insulated by fuses blowing up. Capacitance decreases as function of the ratio between elementary cell surface and total

surface of capacitor, so there is no complete failure and no short circuit, only a minimal capacitance decrease which can be useful as a measure of ageing.

Metallised film capacitors from AVX are designed to meet CEI 1071 standards. This means they are able to handle multiple voltage surges of up to twice the rated voltage, without significantly decreasing product lifetime. It also means the designer need only account for nominal voltage requirements when specifying the system.

Metallised film capacitors also offer significant space savings when compared to devices manufactured using other technologies - such as aluminium electrolytic - if high RMS current handling is a requirement.

AVX has significant experience in developing power capacitors for automotive application, dating back to 1995. Currently the company offers a range of metallised film devices based on cylindrical (puck) or flat bobbin modular building blocks. This approach has several benefits. Firstly, the arrangement of the capacitors can be optimised to suit the available space, resulting in great volumetric efficiency. Second, the arrays are current- and inductance-balanced by AVX and suffer no expansion problems across a temperature range of -55 to +125degC. Lastly, because the individual capacitor building blocks are manufactured on process-controlled, automated lines, quality and cost-effectiveness are assured.

An application note from AVX discusses some design considerations concerning metallised film capacitors used in electric vehicle applications.

DC link filter: high current and capacitance value design

In an electric car or fork lift truck where energy is supplied by batteries the capacitor will be used as for decoupling. Film capacitors are particularly well suited for this use, since the main criteria for DC link application is the device's RMS current withstanding capability.

If we take the following typical electric car data:

Working voltage: 120Vdc

Ripple voltage (U_{ripple}) allowed: 4Vrms

RMS current (I_{rms}): 80Arms @ 20kHz

The minimum capacitance value will be determined from the equation:

$$C = I_{\text{rms}} / (U_{\text{ripple}} \times 2\pi f) = 159\mu\text{F}$$

If we were to attempt the same calculation using electrolytic technology we need to take into account the fact that you need a $1\mu\text{F}$ capacitor to handle 20mA, so in our example, in order to handle 80 Arms the minimum capacitance value would be:

$$C = 80 / 0.02 = 4000\mu\text{F}$$

Therefore we see it is much better to use a much lower rated film device, saving cost and space.

Overvoltage

If we consider the example of light traction application, such as metros, tramways or electric buses, the DC link voltage wave form is represented in figure 1.

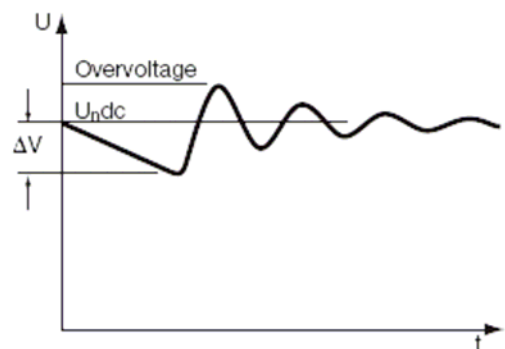
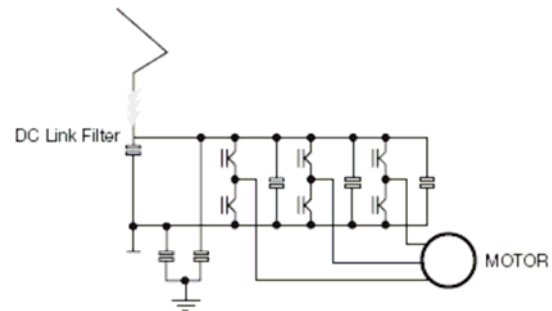

Figure 1: DC link voltage wave form

In such applications, discontinuities can occur when power is transferred between from the catenary or messenger wire to the train. When contact is not completed, energy flows from the DC link filter, decreasing the voltage. Therefore, as soon as the contact is re-established, an overvoltage appears. In the worse case the voltage change would be equal to twice the catenary voltage, resulting in an overvoltage almost twice the rated voltage. However, film capacitors can handle this level of overvoltage.

In comparison, to do the same task using electrolytic technology the capacitors would need to be significantly larger - around twice

the size for a rated voltage of 1000V, reaching a surge voltage of 2000V.

Protection of semiconductors

The first electric vehicle applications used thyristor technology, but subsequently many applications are now based around IGBTs. DC link capacitor development has had to match the evolutions in semiconductor technology not only electrically, but also mechanically to deliver the lowest parasitic inductance. AVX offers several families of film capacitors designed to operate optimally with both thyristors and IGBTs.

As an example of the success AVX has enjoyed with its power film capacitor families, products supplied by the company helped break the world speed record for conventional trains. In April, 2007, a French-made TGV boasting a 19.6 MW (over 26,000-horsepower) capacity and special wheels reached 574.8 km/h (357.2 mph), beating the previous record of 515.3 km/h (320.2 mph) set in 1990.

The high energy power film capacitors used in the TGV are part of the Trafim™ family. They offer significantly reduced weight and volume

and are specified at 3mF, 1890Vdc (DKTFM546); 2.5 mF, 2630 Vdc (DKTFM603); 1.67 mF, 4000 Vdc (DKTFM537); and 1mF, 4000Vdc (DKTFM538).



Figure 2: Trafim

More, AVX's metallised film capacitors exhibit exceptional reliability in the field. No catastrophic field failures have ever occurred over the company's history of having shipped over 150,000 big oil filled DC filter products to customers and accumulated in excess of 3 billion hours of operational life in a variety of harsh and demanding applications.



NORTH AMERICA
Tel: +1 864-967-2150

ASIA
Tel: +65 6286-7555

CENTRAL AMERICA
Tel: +55 11-46881960

EUROPE
Tel: +44 1276-697000

JAPAN
Tel: +81 740-321250

NOTICE: Specifications are subject to change without notice. Contact your nearest KYOCERA AVX Sales Office for the latest specifications. All statements, information and data given herein are believed to be accurate and reliable, but are presented without guarantee, warranty, or responsibility of any kind, expressed or implied. Statements or suggestions concerning possible use of our products are made without representation or warranty that any such use is free of patent infringement and are not recommendations to infringe any patent. The user should not assume that all safety measures are indicated or that other measures may not be required. Specifications are typical and may not apply to all applications.

WWW.KYOCERA-AVX.COM