

TECHNICAL PAPER

Film Technology to Replace Electrolytic Technology

Gilles Terzulli

KYOCERA AVX Components Corporation
Avenue du Colonel Prat 21850
St Apollinaire France

Billy W. Peace

KYOCERA AVX Components Corporation
802 17th Ave. South
Myrtle Beach, SC 29578

Abstract

Since 1980, great improvements have been made on DC filter capacitors using a combination of metallized plastic films and different segmentations of the metallization on those film dielectrics. Volume and weight have been reduced by a factor of 3 or 4 over the last years. Now film manufacturers have developed thinner films and have improved segmentation techniques used on the metallization which has helped immensely in the improvement of such capacitors. Using non-gas impregnated designs, the voltage ranges between 600 VDC and 1200 VDC can be more economically covered by film capacitors rather than electrolytic. Depending on the application, over 1200 VDC, vegetable oil-filled versions are recommended.

Consequently, the trend of industrial and traction market for power conversion is to replace electrolytic capacitors with film technology. This trend is generated by many advantages that film technology offers. These include: high rms current capabilities up to 1ARMS per μF , over voltage withstanding up to 2 times the rated voltage, handle voltage reversal, high peak current capabilities, no acid inside, long lifetime, no storage problem.

However, this replacement won't be done "microfarad for microfarad", but for the total function. Indeed, despite the very big improvement of film technology, replacement solution won't be possible for each application. In order to help the user understand, we will present some concrete figures where film gives major benefits over electrolytic technology.

FILM TECHNOLOGY TO REPLACE ELECTROLYTIC TECHNOLOGY

Gilles Terzulli

KYOCERA AVX Components Corporation
Avenue du Colonel Prat 21850 St Apollinaire France
Phone: +33 3 80 71 75 28 Fax: +33 3 80 71 76 85

Billy W. Peace

KYOCERA AVX Components Corporation
802 17th Ave. South Myrtle Beach, SC 29578
Phone: 843-946-0440 Fax: 843-916-7765

Metallized Technology

Principle

We coat on a dielectric film, metallic layers thin enough, so that in case of dielectric defect, this coat can volatilize and consequently isolate the defect. This phenomenon is called self-healing.

Technique of metallization

As the first step, polymer film (polypropylene) is treated (corona or other) so that molecular metal can be attached.

Metallized layers are formed by metal evaporation under vacuum (1200°C for aluminium) that condenses on the treated surface of film (the film is cooled to a temperature of -25°C to -35°C).

SCHEMATIC DIAGRAM OF THIS EQUIPMENT

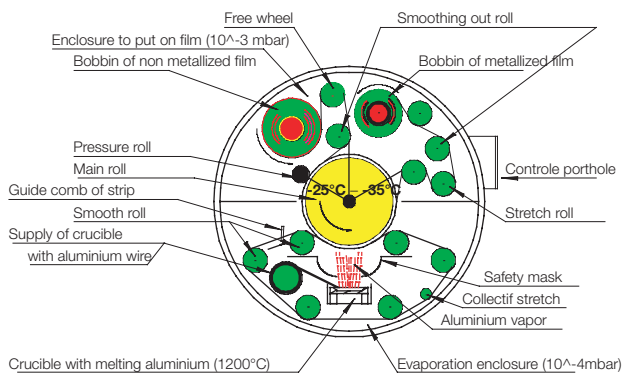

This metallized film results in the principle of self-healing which is the major reason for the increase in gradient of voltage. Even if polymer quality improves a lot, main developments are done on metallization.

Today, with a total dry technology, gradient of voltage can reach more than $500\text{V}/\mu\text{m}$ for discharge application and $250\text{V}/\mu\text{m}$ for DC filtering application.

As these capacitors are designed to withstand CEI 1071 standard, they can withstand several voltage surges of up to twice rated voltage without significantly

decreasing lifetime. Therefore, the user only needs to take into account the nominal voltage that he needs.

Electrolytic Capacitors Technology

Electrolytic capacitors use dielectric properties of aluminium corrosion, which is alumina. The dielectric constant of aluminium is between 8 and 8.5, and the working gradient of voltage is about $0.07\text{V}/\text{\AA}$. Consequently for 900V_{DC} aluminium thickness of 12000\AA or $1.2\mu\text{m}$ would be required.

However it is not possible to reach such thickness, because in order to have a good specific energy, aluminium foil has to be pitted. And obviously there is a ratio between aluminium engraving and aluminium thickness. Thickness of aluminium reduces capacitance coefficient of aluminium engraving and for example, for a 500V capacitance gain is divided per 2 compared to a low voltage capacitor.

In other hand, with high voltage (500V) electrolyte conductivity reaches $5\text{ k}\Omega\text{cm}$ compared to $150\text{ }\Omega\text{cm}$ for low voltage, which limits rms current value at about 20mA per μF .

For these reasons, maximum nominal voltage for this technology is typically 500 to 600 Volts. Therefore, the user must connect several capacitors in series for higher voltage applications. And, as the insulating resistance of these capacitors can vary from capacitor to capacitor, the user must connect a resistance to each capacitor to balance the voltage.

On the other hand, if a reverse voltage higher than 1.5 times the rated voltage is applied, a chemical reaction occurs. And if this reversal of voltage lasts long enough, the capacitor will explode, or the electrolyte will leave by an eventual pressure release. To avoid this risk, user has to connect a diode in parallel with each capacitor.

The last point, which is for certain applications one of the most important, is the surge voltage withstanding capability. Indeed, maximum permissible surge voltage for electrolytics is 1.15 or 1.2 (for the better) V_{NDC} . This obliges the user to take in account not the nominal voltage but the surge voltage.

DC Link Filter: High Current Design & Capacitance Value Design

a) Energy supplied with batteries

Applications will be electric car, or electric fork lift truck.

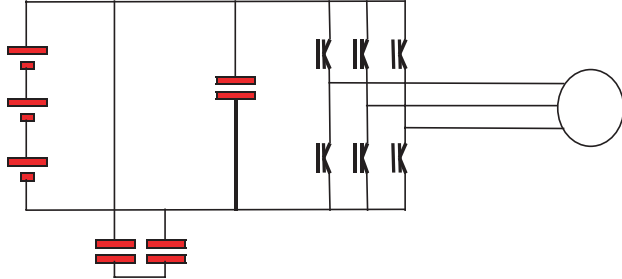

In that case, the capacitor will be used for decoupling.

Film capacitors are particularly well adapted for this use, because the main criteria for DC link capacitor is the ability to withstand rms current.

It means that DC link capacitor can be designed on rms current value.

If we take an electric car in account as example:

Requirement data:

Working voltage:	120V _{DC}
Ripple voltage allowed:	4V _{RMS}
Rms current:	80 A _{RMS} @ 20 kHz

Minimum capacitance value will be:

$$C = \frac{I_{rms}}{U_{ripple} \times 2 \times \pi \times f} = 159 \mu F$$

So, it will be easy to find a capacitance value close to this value.

Comparison with electrolytic capacitor:

If we take in account 20mA per μF for example, in order to handle 80 Arms, capacitance value minimum would be:

$$C = \frac{80}{0.02} = 4000 \mu F$$

b) Industrial motor drive, energy supplied from supply network:

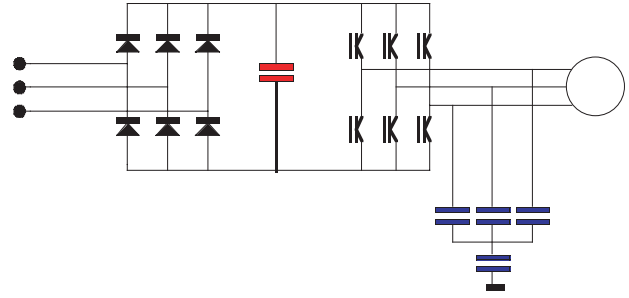

DC link voltage waveform:

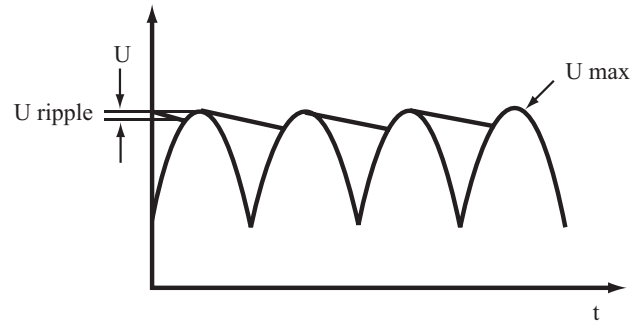

Capacitance value will be defined taking in account that the supply frequency is lower than converter frequency.

To determine needed capacitance, we can use the following equation:

$$C = \frac{P_{load}}{U_{ripple} \times \left[U_{max} - \frac{U_{ripple}}{2} \right] \times F_{rectifier}}$$

I_{RMS} through capacitor will be (approached expression):

Of course this current doesn't take in account frequency converter current.

$$I_{rms} = \frac{U_{ripple}}{2 \times \sqrt{2}} \times C \times 2 \times \pi \times F_{rectifier}$$

$$I_{rms} = \frac{P_{load} \times \pi}{\left[U_{max} - \frac{U_{ripple}}{2} \right] \sqrt{2}}$$

So, with this approximation, I_{RMS} through the capacitor will be depending of the Power of load, U_{max} and U_{ripple}.

To illustrate, we will take a concrete example:
 DC voltage 1000 Volts
 U ripple 200 Volts

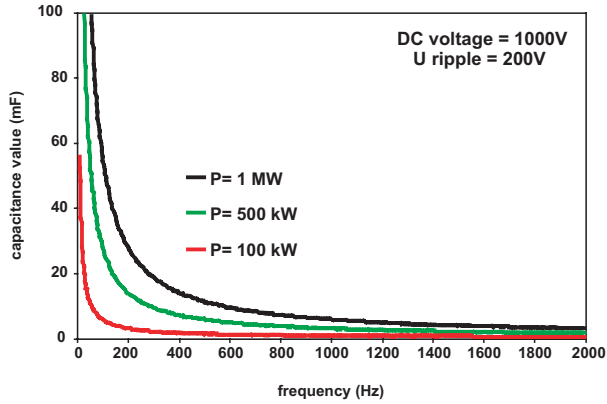

I_{RMS} :
 (P=1MW) = 2468 Arms
 (P=500kW) = 1234 Arms
 (P=100kW) = 247 Arms

It becomes necessary to have a zoom on low frequency:

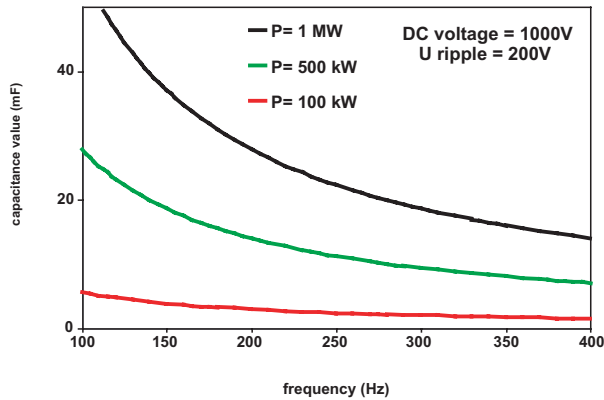

To compare with electrolytic solution, we will take a current capability of 20mA per μF for electrolytic capacitors.

First case, power at 1MW.

Rms current is 2468 A_{RMS} , which would impose minimum capacitance value of 123.4mF (taking in account $0.2A_{RMS}$ per μF).

If we look at this value on the curve, we can see that this capacitance value is needed (with the given example for film technology) for a rectifier frequency lower than 100Hz.

So, with 3 phases, 6 diodes rectifier, frequency will be 300Hz.

We can see for 1 megawatt curve that capacitance needed is 18.5mF. Film solution will be almost 4 times smaller than electrolytic solution, and with high reliability.

Lower power will give similar results, and for power up to 10 kwatts, capacitance value becomes so small that film technology still constitutes best solution.

Even at 100Hz rectifier frequency, no more than 555 μF are needed, supply voltage and ripple are still the same as before.

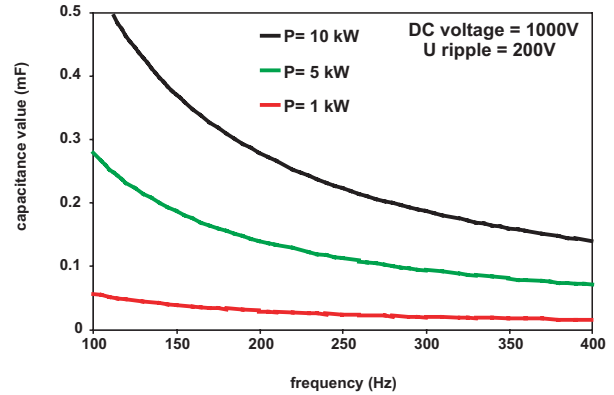

Over Voltage Design

We will now consider light traction applications, like metro, tramway, electric buses, etc.

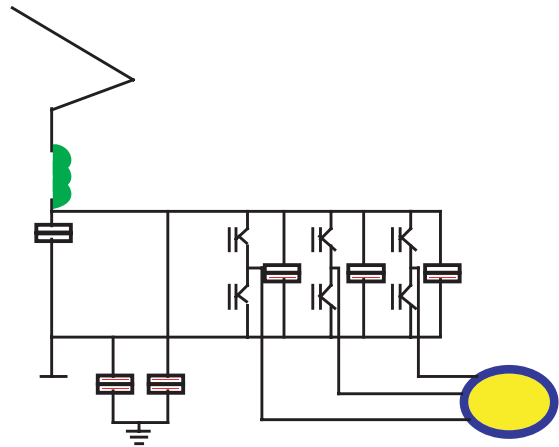

DC link voltage waveform:

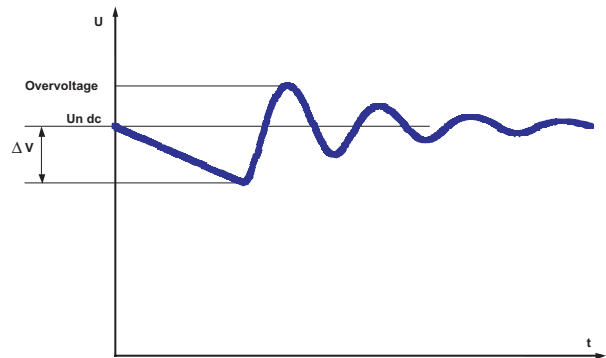

Due to the principle of carrying the power from the catenary's to the train, some contact discontinuity appears between pantograph and catenary's.

When contact is not made, energy comes from the DC link filter, with for effect, to decrease the voltage. So, as soon as the contact is re-established, an over voltage appears.

$$V(t) = U_{ndc} - \Delta V \times e^{-\alpha t} \times \left(\cos \omega t + \frac{\alpha}{\omega} \sin \omega t \right)$$

with $\omega = \sqrt{\beta_0^2 - \alpha^2}$

$$\beta_0 = \frac{1}{\sqrt{L \times C}}$$

$$\alpha = \frac{R}{2 \times L}$$

Worse case would be $\Delta V =$ catenary's voltage, because over voltage could almost reach 2 times the rated voltage.

So, film capacitors can handle this kind of over voltage.

Comparison with electrolytic technology:

Electrolytic handles 1.2 DC voltage max:

So minimum voltage that electrolytic should handle would be:

DC voltage of electrolytic technology:

$$\frac{2 \times 1000V}{1.2} = 1670V$$

Four (4) capacitors 450 Volts in series would be needed.

Taken in account some data found on the WEB,

Volume occupied for 10mF with electrolytic would be: 26 l, and I_{RMS} max would be 220A_{RMS}.

With film, volume occupied would be 25 l, and rms current capability would be higher than 500A_{RMS}.

On the other hand, due to these over voltages, peak current appears through the capacitor.

So, we have to calculate the energy generated by this over voltage $I^2t = \int i^2(t) dt$.

$$i(t) = \frac{C \beta_0^2 V_0}{\omega} e^{-\alpha t} \sin \omega t$$

$$i^2(t) = \frac{C^2 \beta_0^4 V_0^2}{\omega^2} e^{-2\alpha t} \sin^2 \omega t$$

$$\int_0^\infty i^2(t) dt = \left[\frac{1}{4} \frac{e^{-2\alpha t} C^2 \beta_0^4 V_0^2 (-\alpha^2 - \omega^2 + \alpha^2 \cos 2\omega t - \alpha \omega \sin 2\omega t)}{\alpha \omega^2 (\alpha^2 + \omega^2)} \right]_0^\infty$$

After few periods, current become null, then:

$$\int_0^\infty i^2(t) dt = [0] - \left[-\frac{1}{4} \frac{C^2 \beta_0^4 V_0^2}{\alpha (\alpha^2 + \omega^2)} \right] = \frac{1}{4} \frac{C^2 \beta_0^4 V_0^2}{\alpha (\alpha^2 + \omega^2)}$$

With: $\beta_0 = \frac{1}{\sqrt{L \times C}}$; $\alpha = \frac{R}{2 \times L}$; $\omega = \sqrt{\beta_0^2 - \alpha^2}$

This energy calculation will be used for short circuit discharge between terminals as well. Such discharge will generate a very high peak current and some ringing that electrolytic could not handle.

Voltage Rating

Function of the voltage rating needed, film solution will become more and more interesting.

If high capacitance value is requested, film solution will be less competitive. Indeed, if there is no over voltage, low rms current, large capacitance value, it will be difficult for film technology to be competitive below 900 Volts.

Lifetime Calculation

Film technology allows a very long lifetime expectancy, depending of voltage load conditions (working voltage) and hot spot temperature.

For DC filtering, lifetime meets the following curves:

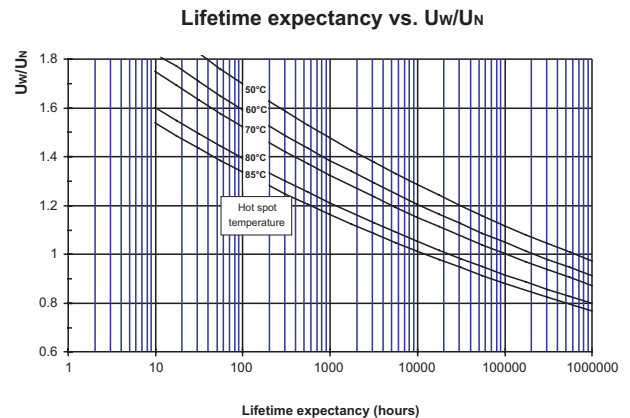

As we can see on these curves, design is done for a lifetime of 100,000 hours under the rated voltage and 70°C hot spot.

End of life criteria is a decrease of capacitance value of 2%. However, this is a theoretical end of life, because the capacitor can still be used beyond this point. If the application allows 5% capacitance decrease, lifetime will be widely increased.

Hot spot temperature will be determined with the following expression:

$$\theta_{\max \text{ hotspot}} = \theta_{\text{ambient}} + I^2_{\text{rms}} \times \left[r_s + \frac{1}{C \times 2 \times \pi} \times \text{tg} \delta_0 \right] \times R_{th}$$

with $\theta_{\max \text{ hotspot}}$: the maximum hot spot temperature

$\text{tg} \delta_0$: dielectric losses

R_{th} : thermal resistance

r_s : serial resistance

$\theta_{\text{hot spot}}$ will be 85°C or 105°C function of the application and the technology.

Metallized Film DC Filtering Capacitors – New Innovations and Advantages for Use

With the strong semi-conductor evolution, the requirement for DC link filters moved in a way where stray inductance has to decrease dramatically in order to limit over voltage due to semi-conductor commutation.

Here again, Film Technology offers the solution, and responds to the market.

AVX TPC is working very closely with its customers, has developed a capacitor which can be directly mountable onto the new IGBT modules offering a major advantage that the bus bar between the IGBT module and capacitor is no longer required.

Following are two examples of such a design:

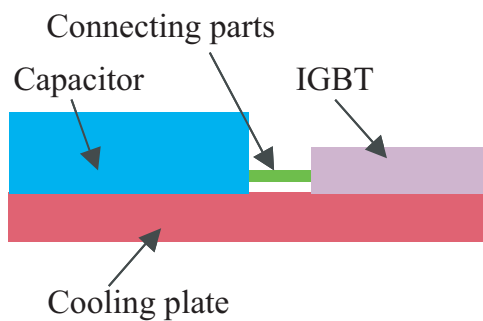

On the example above, capacitor is directly screwed onto the IGBT module, using its own terminals.



The design of this capacitor also takes in account a very important customer requirement which is protection against the environment.

Indeed, lifetime of this capacitor is based on traction applications, meaning resulting in a long lifetime expectancy of higher than 100,000 hours under nominal electrical and environmental conditions.

In order to achieve this lifetime the capacitor uses a plastic or aluminium box, hermetically sealed by a polyurethane resin. This polyurethane resin allows not only a total protection against the environment, but also allows the capacitor to meet the NF F 16-101 and NF F 16-102 fire behavior standards for railway rolling stock which is not possible for a non encapsulated design.

In addition, this resin filled technology allows the use of different types of terminals, for example a large copper plate terminal separated by an insulating sheet as illustrated below. A metallic top could not allow such type of terminals to be used.

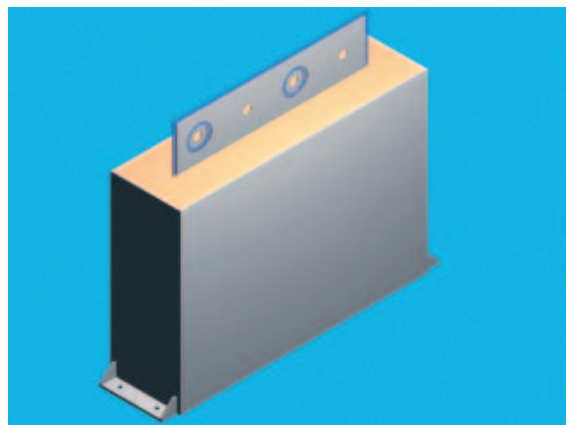

Designs for lower lifetime expectancy can be also made, using the same technology, but by increasing the gradient of voltage, which increases the energy density. Ageing laws have been determined and software developed in order to be able to answer to any specific customer request.

Another important point is the innovative internal mounting allowing for a very low stray inductance. Only a very specific technology can be used to achieve a stray inductance of lower than 10nH, even for large capacitors. As a result it becomes no longer necessary to use decoupling IGBT capacitors, saving even more on cost.

Conclusion

In this presentation, we have offered guidelines to help engineers optimize their designs. As each situation will be different, complete calculation will be necessary. However, if requirement is for low voltage, low rms current, no voltage reversal, and no peak current, film technology may not be suitable. But, if the application requires high voltage, high rms current, over voltage considerations, voltage reversal, high peak current, and long lifetime, there is no better choice than power film technology.



NORTH AMERICA
Tel: +1 864-967-2150

ASIA
Tel: +65 6286-7555

CENTRAL AMERICA
Tel: +55 11-46881960

EUROPE
Tel: +44 1276-697000

JAPAN
Tel: +81 740-321250

NOTICE: Specifications are subject to change without notice. Contact your nearest KYOCERA AVX Sales Office for the latest specifications. All statements, information and data given herein are believed to be accurate and reliable, but are presented without guarantee, warranty, or responsibility of any kind, expressed or implied. Statements or suggestions concerning possible use of our products are made without representation or warranty that any such use is free of patent infringement and are not recommendations to infringe any patent. The user should not assume that all safety measures are indicated or that other measures may not be required. Specifications are typical and may not apply to all applications.

WWW.KYOCERA-AVX.COM