

# ARTICLE

## **Practical Capacitor Tolerance Selection for Coupling, DC Blocking and Bypass Applications**

---

### INTRODUCTION

Proper selection of suitable capacitor tolerances is governed to a great extent by the type of application under consideration. This point should always be taken into account when designing for the best balance between cost and performance. For example, DC blocking, coupling and bypassing applications are not very sensitive to the variations in capacitor value that are due to the choice of wide spread tolerances. In contrast, applications such as filtering and matching will usually require narrow spread capacitance tolerances in order to meet the specific demands of those designs.

This discussion will examine the impact of capacitor tolerance on overall circuit performance and will focus on DC blocking, coupling and bypassing applications. Pertinent electrical parameters such as the equivalent series resistance (ESR), series resonant frequency (FSR), magnitude of the impedance (Z<sub>c</sub>), capacitor RF current (I<sub>c</sub>), power dissipated by the capacitor (P<sub>cd</sub>) and reflection coefficient (ρ) will be considered. **Table 1** illustrates the relationship between ESR, F<sub>SR</sub> and Z<sub>c</sub> for selected capacitance values and tolerances. All devices referenced therein are 100A series (55 mil by 55 mil) porcelain chip capacitors. **Table 1** also shows the deviation from the nominal capacitor impedance, in ohms, for various tolerances and lists impedance deviations from 50 ohms as a percentage for all capacitance values listed.

### COUPLING

When designing capacitors into DC blocking and coupling applications, a suitable capacitance value must first be selected in order to meet the primary requirements of the design.

The most essential capacitor parameters to evaluate for these applications are series resonant frequency (F<sub>SR</sub>), magnitude of impedance (Z<sub>c</sub>), and equivalent series resistance (ESR). A coupling capacitor is best selected so that its impedance is as low as possible at the frequency of interest. The impedance magnitude at any frequency is easily calculated as:

$$Z = \sqrt{ESR^2 + (X_L - X_C)^2}$$

Since the net reactance is zero at the capacitor's F<sub>SR</sub>, the total impedance will be equal to the ESR at this frequency. Therefore, the ideal capacitor intended for a coupling application will have an F<sub>SR</sub> that corresponds to the operating frequency. The capacitor values listed in **Table 1** are EIA standard values and tolerances. They have been deliberately chosen to represent the nearest standard values associated with common wireless frequency applications. All impedance data presented in **Table 1** is referenced to each nominal capacitor value. Likewise, the

deviation in impedance from an ideal 50-ohm system has been tabulated as a percentage.

The following example describes a typical coupling application for a 20-watt (43 dBm) 1.87 GHz single channel power amplifier. The current through the coupling capacitor (I<sub>c</sub>) will be calculated for an ideal 50-ohm (50 + j0) load impedance. A 27 pF nominal coupling capacitor is used in the following example and is depicted as CC in **Figure 1**. The results obtained for the calculation of power dissipated (P<sub>cd</sub>) by the 27 pF coupling capacitor will be used as a baseline. This calculation will be repeated for the 27 pF ±10% capacitor values and these results

A capacitor's series resonant frequency (F<sub>SR</sub>) also referred to as self-resonance, occurs at will be compared to the baseline.

Since coupling capacitor C<sub>c</sub> is in series with the load, the current flowing through C<sub>c</sub> and R<sub>L</sub> are equal and can be calculated by:

$$I_c = \sqrt{P/Z} \text{ or } \sqrt{20/50} = 0.632 \text{ ma.}$$

Therefore the power dissipated by the capacitor (P<sub>cd</sub>) is then calculated by:

$$P_{cd} = I_c^2 \times ESR$$

- Calculate P<sub>cd</sub> for 27 pF nominal

$$P_{cd} = (0.632)^2 \times 0.159 \\ = 63.51 \text{ mW}$$

- Calculate P<sub>cd</sub> for 27 pF, ±10%

$$27 \text{ pF} + 10\% = 29.7 \text{ pF,} \\ P_{cd} = (0.632)^2 \times 0.154 \\ = 61.51 \text{ mW}$$

$$27 \text{ pF} - 10\% = 24.3 \text{ pF,} \\ P_{cd} = (0.632)^2 \times 0.166 \\ = 66.30 \text{ mW}$$

From this example, it can be seen that the difference in P<sub>cd</sub> between the nominal 27 pF value and the value corresponding to the worst case tolerance (24.3 pF) is about 2.8 mW. This corresponds to 0.014% of the total power. Even with the most stringent design requirements imposed, the comparative difference in P<sub>cd</sub> is infinitesimal and will not affect the end performance of this circuit in any significant manner.

Given the same 27 pF capacitor, a comparison between the nominal capacitance and output match will be calculated.

**TABLE 1. ELECTRICAL PARAMETERS FOR SELECT KYOCERA AVX  
100A SERIES 55-MIL X 55 MIL PORCELAIN CHIP CAPACITORS**

Capacitance and Tolerance	ESR	F <sub>SR</sub> (MHz)	Impedance Magnitude Z <sub>C</sub> (Ohms)	Deviation of Z <sub>C</sub> from nominal Z <sub>C</sub> (Ohms)	Deviation of Z <sub>C</sub> from 50 ohm Network %
Nominal (7.5 pF)	0.346	3460	0.35	0	0.70
+ 0.1 pF (7.6 pF)	0.344	3440	0.35	0	0.70
- 0.1 pF (7.4 pF)	0.347	3490	0.36	0.01	0.72
Nominal (7.5 pF)	0.346	3460	0.35	0	0.70
+ 0.25 pF (7.75 pF)	0.342	3410	0.38	0.03	0.76
- 0.25 pF (7.25 pF)	0.350	3520	0.41	0.06	0.82
Nominal (7.5 pF)	0.346	3460	0.35	0	0.70
+ 5% (7.875 pF)	0.340	3380	0.43	0.08	0.86
- 5% (7.125 pF)	0.352	3550	0.48	0.13	0.96
Nominal (7.5 pF)	0.346	3460	0.35	0	0.70
+ 10% (8.25 pF)	0.334	3310	0.62	0.27	1.24
- 10% (6.75 pF)	0.359	3640	0.76	0.41	1.52
Nominal (16 pF)	0.219	2410	0.22	0	0.44
+ 1% (16.16 pF)	0.218	2400	0.22	0	0.44
- 1% (15.84 pF)	0.220	2420	0.22	0	0.44
Nominal (16 pF)	0.219	2410	0.22	0	0.44
+ 2% (16.16 pF)	0.217	2390	0.23	0.01	0.46
- 2% (15.68 pF)	0.221	2430	0.23	0.01	0.46
Nominal (16 pF)	0.219	2410	0.22	0	0.44
+ 5% (16.8 pF)	0.215	2350	0.29	0.07	0.58
- 5% (15.2 pF)	0.223	2470	0.30	0.08	0.60
Nominal (16 pF)	0.219	2410	0.22	0	0.44
+ 10% (17.6 pF)	0.211	2300	0.42	0.20	0.84
- 10% (14.4 pF)	0.228	2530	0.49	0.27	0.98
Nominal (27 pF)	0.159	1870	0.16	0	0.32
+ 1% (27.27 pF)	0.159	1860	0.16	0	0.32
- 1% (26.73 pF)	0.160	1880	0.17	0.01	0.34
Nominal (27 pF)	0.159	1870	0.16	0	0.32
+ 2% (27.54 pF)	0.158	1860	0.16	0	0.32
- 2% (26.46 pF)	0.161	1890	0.18	0.02	0.36
Nominal (27 pF)	0.159	1870	0.16	0	0.32
+ 5% (28.35 pF)	0.157	1830	0.20	0.04	0.40
- 5% (25.65 pF)	0.162	1920	0.24	0.08	0.48
Nominal (27 pF)	0.159	1870	0.16	0	0.32
+ 10% (29.7 pF)	0.154	1790	0.30	0.14	0.60
- 10% (24.3 pF)	0.166	1970	0.39	0.23	0.78
Nominal (100 pF)	0.072	1000	0.07	0	0.14
+ 1% (101 pF)	0.072	1000	0.07	0	0.14
- 1% (99 pF)	0.073	1000	0.07	0	0.14
Nominal (100 pF)	0.072	1000	0.07	0	0.14
+ 2% (102 pF)	0.072	990	0.08	0.01	0.16
- 2% (98 pF)	0.073	1010	0.08	0.01	0.16
Nominal (100 pF)	0.072	1000	0.07	0	0.14
+ 5% (105 pF)	0.071	980	0.10	0.03	0.20
- 5% (95 pF)	0.074	1020	0.11	0.04	0.22
Nominal (100 pF)	0.072	1000	0.07	0	0.14
+ 10% (110 pF)	0.070	960	0.16	0.09	0.32
- 10% (90 pF)	0.075	1050	0.19	0.12	0.38

Assuming that the match is ideal, the reflection coefficient ( $\rho$ ) resulting from the mis-match losses associated with the coupling capacitor will be calculated. The calculation will be performed for the nominal 27 pF value as well as the  $\pm 10\%$  tolerance values. Given the value of  $\rho$  the VSWR and return loss is ascertained for both the nominal capacitor value as well as for the  $\pm 10\%$  capacitor values.

The reflection coefficient will be calculated in reference to a 50-ohm system. The magnitude of impedance for the 27 pF capacitor will be denoted as  $Z_c$  in this calculation.

$Z_0$  = Characteristic shunt impedance (50 ohms)  
 $Z_c$  = Capacitor impedance (ohms)  
 $Z_x = Z_0 + Z_c$  (ohms)

Reflection Coefficient ( $\rho$ ):

$$\rho = \frac{Z_x / Z_0 - 1}{Z_x / Z_0 + 1}$$

VSWR and Return Loss:

$$VSWR = \frac{1 + \rho}{1 - \rho}$$

Return Loss:

$$RL = 20 \text{ Log } \rho$$

- Match calculations for 27 pF nominal

$Z_c = 0.16 \text{ ohm}$

Therefore  $\rho = 0.0032 / 2.0032 = 0.0015974$

VSWR = 1.0015974 = 1.0032 : 1  
0.9984026

Return Loss = 20 Log 0.0015974  
= -55.93 dB

- Match calculations for 29.7 pF nominal (+10% value)

$Z_c = 0.3 \text{ ohm}$

Therefore  $\rho = 0.0006 / 2.006 = 0.002991$

VSWR = 1.002991 = 1.0056 : 1  
0.997009

Return Loss = 20 Log 0.002991  
= -50.48 dB

- Match calculations for 24.3 pF nominal (-10% value)  
 $Z_c = 0.39 \text{ ohms}$

Therefore  $\rho = 0.0078 / 2.0078 = 0.0038848$

VSWR = 1.0038848 = 1.0078 : 1  
0.9961152

Return Loss = 20 Log 0.002991  
= -48.21 dB

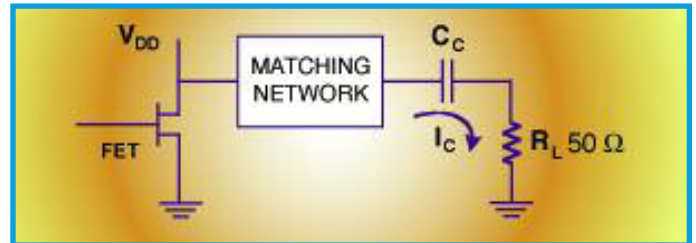

Figure 1. Capacitor  $C_c$  Coupling Application

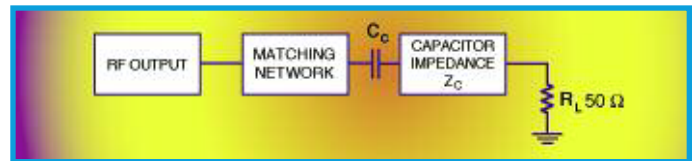

Figure 2. Block Diagram of Amplifier Output Coupled to 50 ohm Load

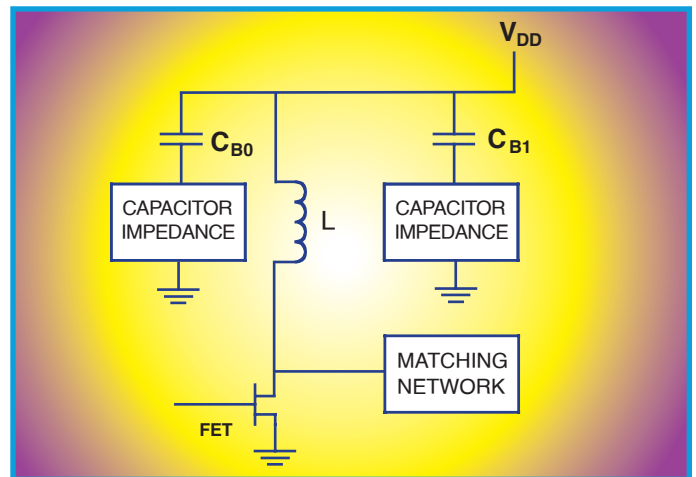

Figure 3. 1.87 GHz Amplifier Output Bias Network

Table 2 is a summary of the results of all match calculations. From these calculations it is clear that the effect of capacitance tolerance is minimal on the magnitude of the impedance and reflection coefficient. In the worst case, the VSWR is 1.0078:1 as compared to 1.0032:1 for the nominal 27 pF capacitor. The differences stated here are also very small and will not affect the output match or end performance in any significant way.

**TABLE 2. REFLECTION PARAMETER COMPARISON DATA FOR KYOCERA AVX 100A270 CAPACITOR**

Capacitance (pF)	Capacitor Impedance ( $Z_C$ ) at 1.87 GHz (ohms)	Reflection Coefficient ( $\rho$ )	VSWR	Return Loss (dB)
27	0.16	0.0015974	1.0032 : 1	-55.93
29.7 (+10%)	0.30	0.002991	1.0056 : 1	-50.48
24.3 (-10%)	0.39	0.0038848	1.0078 : 1	-48.21

### BYPASSING

The function of a bypass capacitor is to offer a low impedance RF path to ground. Accordingly, the capacitor's net impedance will be the main consideration for bypass applications. In the following example CB0 is used to suppress the 1.87 GHz carrier frequency energy, while CB1 will serve to suppress RF energy below the carrier frequencies around 1 GHz. In an actual design there would generally be additional bypass capacitors used in the output bias network to facilitate extended bypass frequency coverage below the carrier frequency. In addition to suppressing RF energy generated by switching pulse edges from an SMPS is continuous and can occur up to frequencies equal to  $0.35/P_E$ , where  $P_E$  is the pulse edge duration in seconds. This noise may be in the range of several hundred MHz requiring larger capacitance values to decouple it from the  $V_{DD}$  supply line.

**Figure 3** depicts a 1.87 GHz amplifier output bias network denoting the  $C_{B0}$  and  $C_{B1}$  bypass capacitors. The selected values for  $C_{B0}$  and  $C_{B1}$  are 27 pF and 100 pF respectively. These values were chosen because they are the nearest standard EIA capacitor value with  $F_{SR}$ 's closely matching the frequencies of interest. Referring to **Table 1** it can be seen that a 27 pF nominal capacitor has an impedance of 0.16 ohms at 1.87 GHz. Since this frequency corresponds to the capacitor's  $F_{SR}$ , the net reactance is zero and therefore the impedance is made up entirely of  $E_{SR}$ . The impedance for the worst-case capacitor tolerances of  $\pm 10\%$ , corresponding to values of 29.7 pF and 24.3 pF, is 0.3 ohms and 0.39 ohms at 1.87 GHz respectively. As delineated in **Table 1**, this represents a 0.6% and 0.78% impedance deviation from a 50-ohm network.

Accordingly, it can be seen that the 100 pF nominal capacitor has an impedance of 0.07 ohms at 1 GHz. The impedance for the worst-case tolerance of  $\pm 10\%$ , corresponding to values of 110 pF and 90 pF, is 0.16 ohms and 0.19 ohms respectively. This represents 0.32% and -55.93 0.38% impedance deviation -50.48 from the 50-ohm network. -48.21

From this example it can clearly be seen that the RF energy to be bypassed by both capacitors at 1.87 GHz and 1 GHz can be easily accomplished with any tolerance value and does not result in a discernible difference in the capacitor's effectiveness in this bypass application.

### CONCLUSION

This discussion pointed out the relative unimportance of using narrow tolerance capacitive elements in  $D_C$  blocking, coupling and bypassing applications. Examples of power dissipation, reflection coefficient and impedance as a function of worst-case capacitor tolerances were presented to further illustrate this point. A table of standard EIA capacitor values suitable for use in a wide range of wireless frequency applications was presented. The table reveals that shifts in capacitor tolerances do not have a significant effect on the overall frequency dependent electrical parameters. It was strongly suggested that wide tolerance capacitors may be used in most coupling and bypass applications without noticeable degradation of the overall circuit performance. This will allow the designer to obtain good module end performance while cutting cost in the process.



**NORTH AMERICA**  
Tel: +1 864-967-2150

**ASIA**  
Tel: +65 6286-7555

**CENTRAL AMERICA**  
Tel: +55 11-46881960

**EUROPE**  
Tel: +44 1276-697000

**JAPAN**  
Tel: +81 740-321250

**NOTICE:** Specifications are subject to change without notice. Contact your nearest KYOCERA AVX Sales Office for the latest specifications. All statements, information and data given herein are believed to be accurate and reliable, but are presented without guarantee, warranty, or responsibility of any kind, expressed or implied. Statements or suggestions concerning possible use of our products are made without representation or warranty that any such use is free of patent infringement and are not recommendations to infringe any patent. The user should not assume that all safety measures are indicated or that other measures may not be required. Specifications are typical and may not apply to all applications.